

MANUREP SALES INC.

FS - 180 - SED

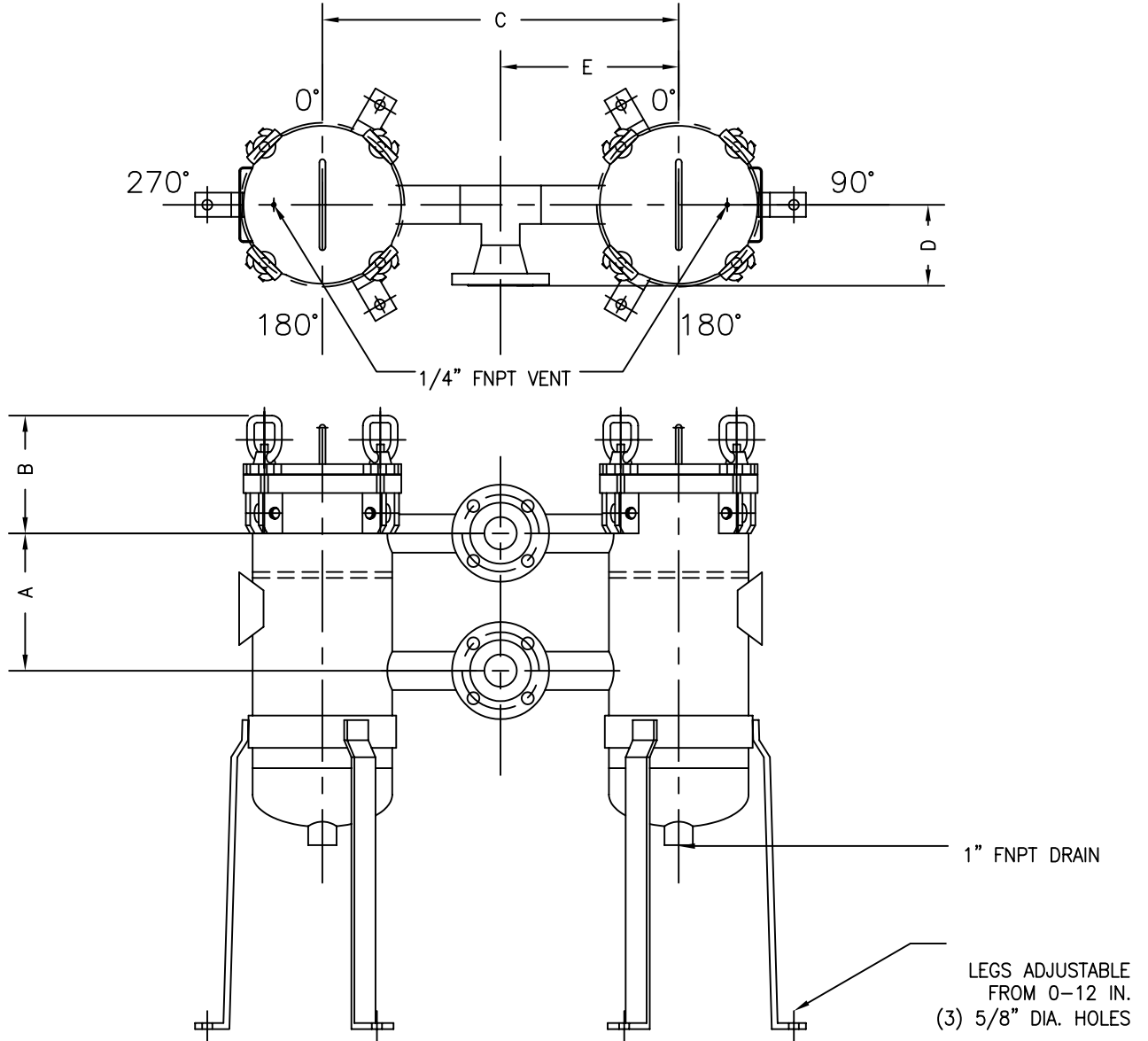

	FITTING SIZE	A	B	C	D	E
STD.	2" FLG	13"	8"	19 3/4"	5"	9 7/8"
	2 1/2" FLG	13"	8"	19 3/4"	5 3/4"	9 7/8"
	3" FLG	13"	8"	19 3/4"	6 1/8"	9 7/8"

SHIPPING WEIGHT	200 lbs
VOLUME	8 1/2 US. gal.
DESIGN PRESSURE	150 psig. @ 225 F