

MANUREP SALES INC.

FS - 180D

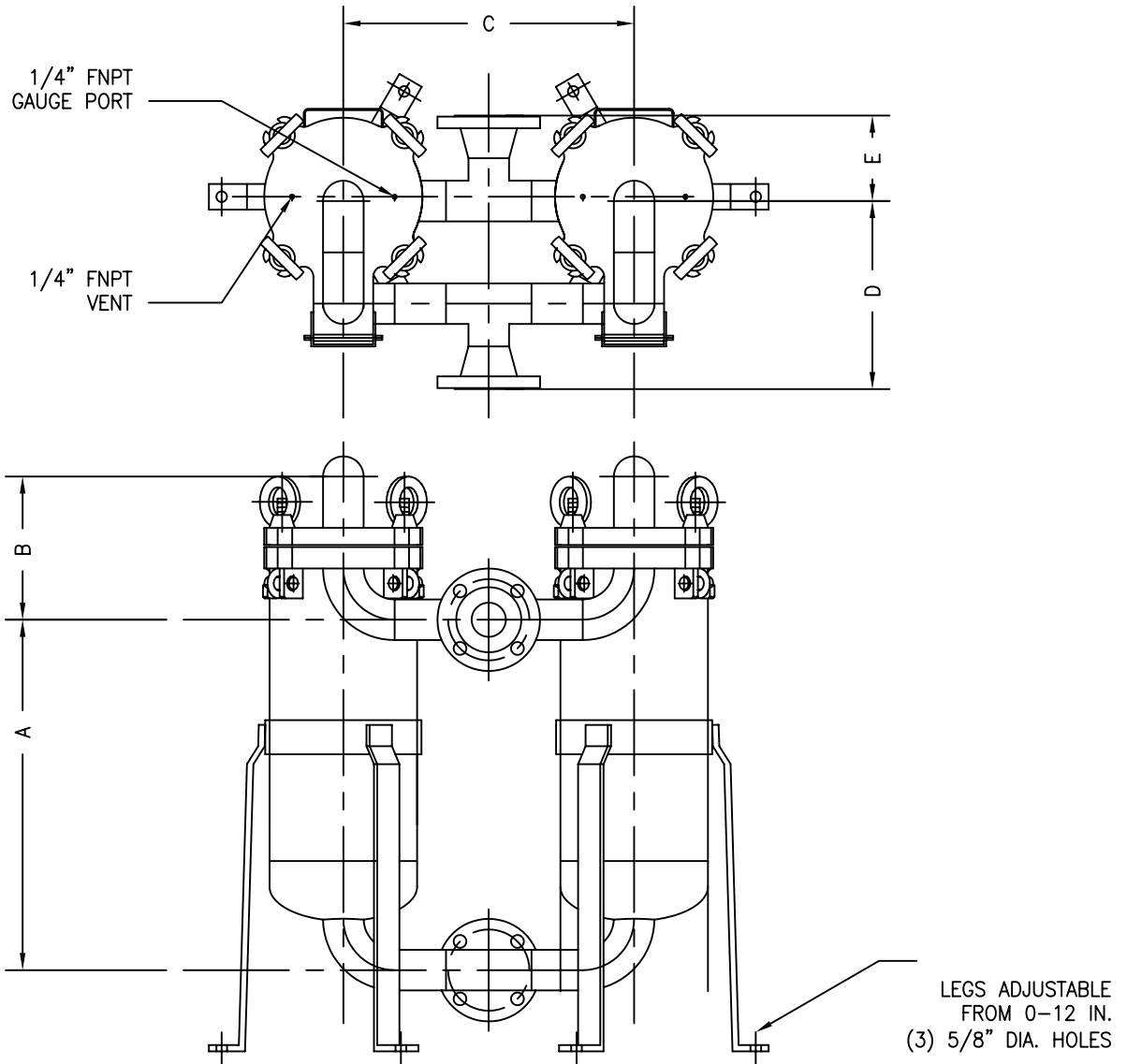

	FITTING SIZE	A	B	C	D	E
STD.	2" FLG	17 1/2"	8"	11"	11"	5"
	2 1/2" FLG	17 1/2"	8"	19"	11 3/4"	5 3/4"
	3" FLG	17 1/2"	8"	19 3/4"	12 1/8"	6 1/8"

SHIPPING WEIGHT	220 lbs
VOLUME	8 1/2 US. gal.
DESIGN PRESSURE	150 psig. @ 225 F