

# MANUREP SALES INC.

FS - 20

STYLE ONE

STYLE TWO

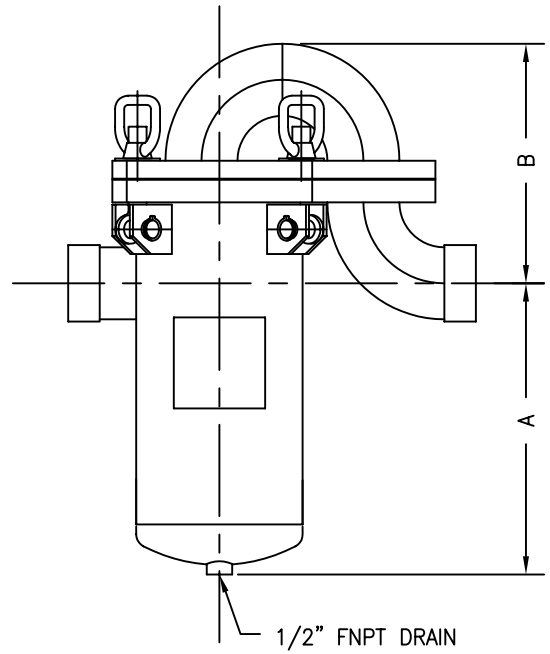
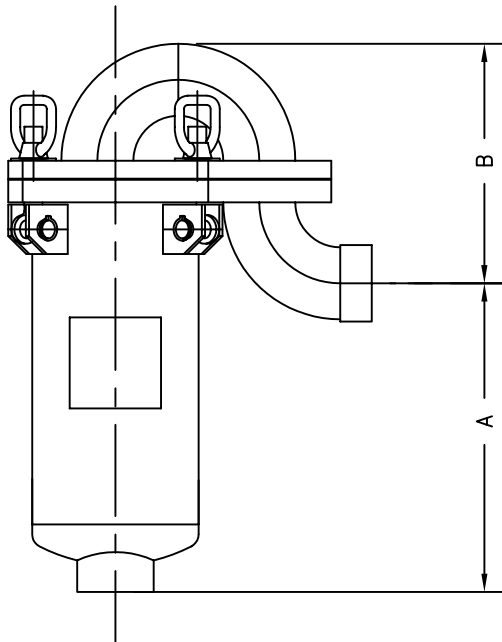
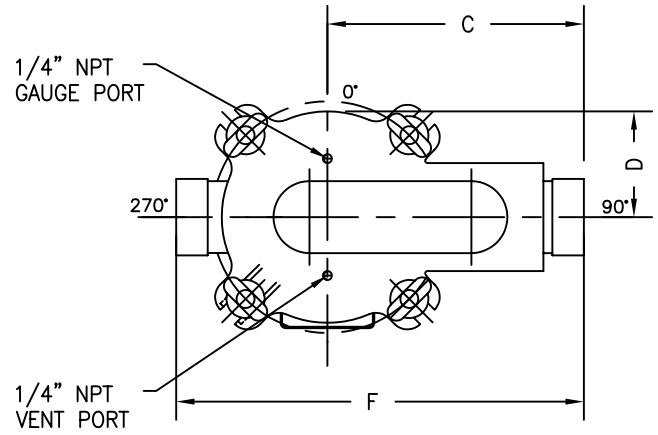
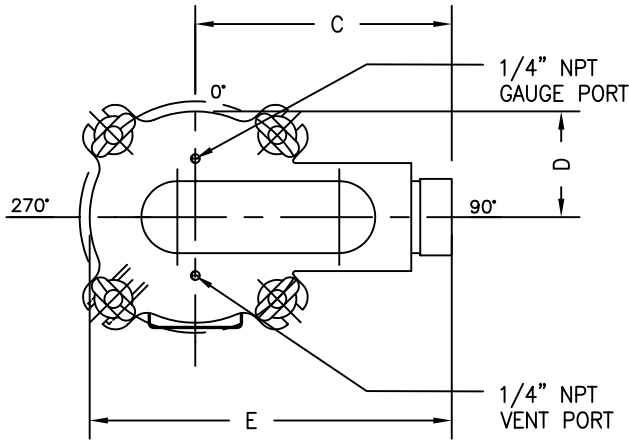

STD.

FITTING SIZE	A	B	C	D	E	F
1" FNPT	7"	6 3/4"	7 3/8"	2 7/8"	10 3/16"	11 3/4"
1 1/2" FNPT	7"	6 3/4"	7 3/8"	2 7/8"	10 3/16"	11 3/4"

SHIPPING WEIGHT	19 lbs.
VOLUME	1/2 US. gal.
DESIGN PRESSURE	150 psig. @ 225 F